

PROPORTIONAL VALVE FOR FLOW CONTROL OR PRESSURE CONTROL ON PNEUMATIC SYSTEM *SERVOTRONIC*

3

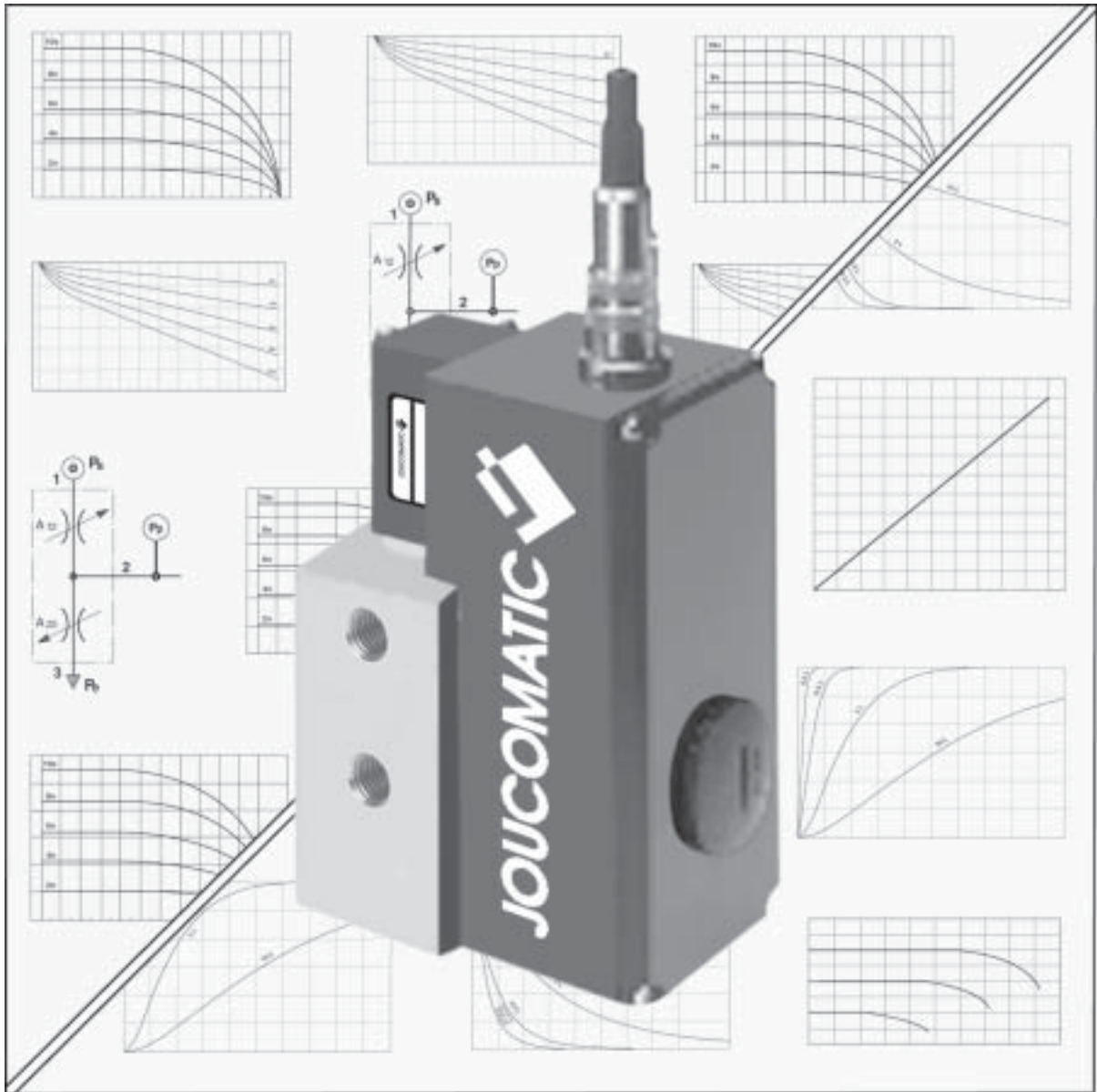

P 330-GB-R0a

THE PROPORTIONAL PNEUMATIC SERVOTRONIC

The flexibility of pneumatics
combined with smart electronics
for greater utilization versatility
of electropneumatic components

INTRODUCTION

The evolution in the automation process is moving towards a need of obtaining greater versatility and increased precision in compressed air driven equipment. This means obtaining proportional operation of the power element as a function of an electric control signal. Combining pneumatic technology and high precision mechanicals is a speedy way of accurately controlling FLOW or PRESSURE values of a pneumatic power system according to a signal obtained from the control electronics.

SERVOTRONIC G 1/4 operates in the following scales of values:

For **flow** control : 0 - 1400 l/min (ANR) with a $\pm 10V$ set-point signal.

For **pressure** control : choice of 7 control ranges, 0 - 0.1 to 0 - 16 bar.
with a 0 - 10V, 0 - 20mA or 4 - 20mA set-point signal.

These modern design products offer high levels of performance.

THE ADVANTAGES OF THE SERVOTRONIC RANGE

- Very short response times
- Very low hysteresis
- Excellent flow-rate performance
- 2 versions proposed: for flow or pressure control
- Compact monoblock assembly with built-in electronics and sensor
- Electrical connection by plug-in connector
- High reliability and long life duration thanks to:
 - A high precision mechanism combined with simple kinematics
 - Very light mobile equipment with small displacements
 - High quality components
- Various possibilities of input set-points (voltage and current) for the pressure control version

APPLICATION AREAS

The performance and the two-fold capability of the SERVOTRONIC range directly responds to pressure or flow control requirements and, indirectly, to many other physical quantities such as : positions, speeds, accelerations, forces, quantities of material, etc. The industrial applications of these systems address many activity areas : packaging and preservation, handling, processing of wood, paint, agro-food, etc.

Application examples :

- spray guns with controlled air pressure or flow,
- precise and fast pressure adjustment,
- pneumatic actuator force control,
- pneumatic turbine speed control,
- pneumatic screwdriver speed control,
- neutral gas flow and proportioning control,
- mechanical entrainment speed regulation,
- dosing and transport of powders,
- active load damping (mother roll receiver in the paper-making industry for instance),
- active load stabilization when affected by spurious movements,
- pneumatic positioning.

EXAMPLE - APPLICATION DIAGRAM TYPES

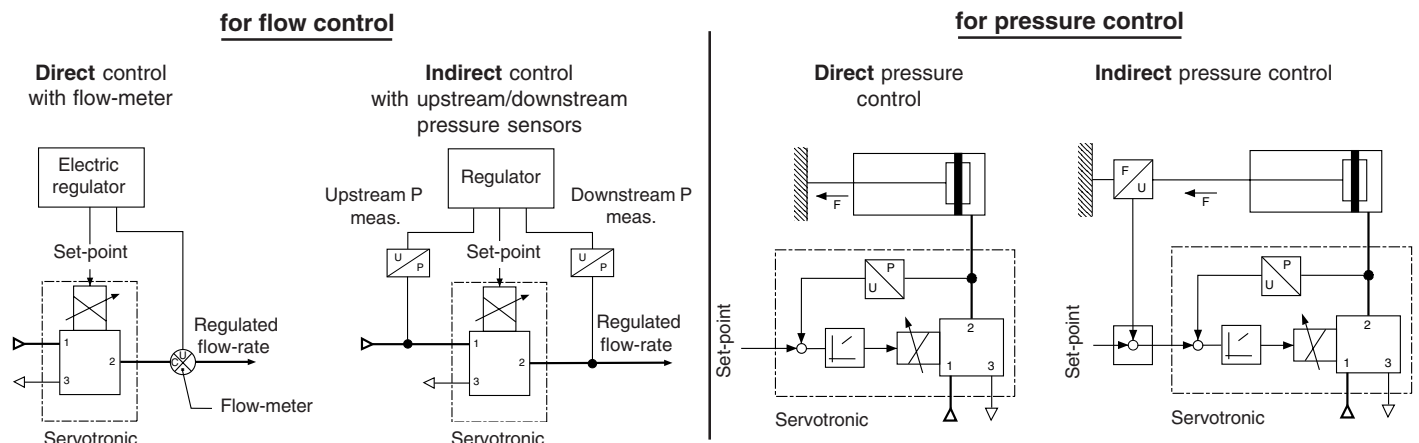

All leaflets are available on: www.ascojoucomatic.com

THE PROPORTIONAL PNEUMATIC SERVOTRONIC

SERVOTRONIC ON FLOW CONTROL

The SERVOTRONIC series 607 flow control version is a 3 port/3 position slide servovalve with an electronic control supplying a flow-rate proportional to a given set-point.

The product includes :

- a pneumatic distributor consisting of matching **spool-sleeve assembly**.
- a **proportional electromagnet** directly controlling the movement of the spool.
- a **position sensor** supplying a signal proportional to the position of the spool and indicating the flow-rate.

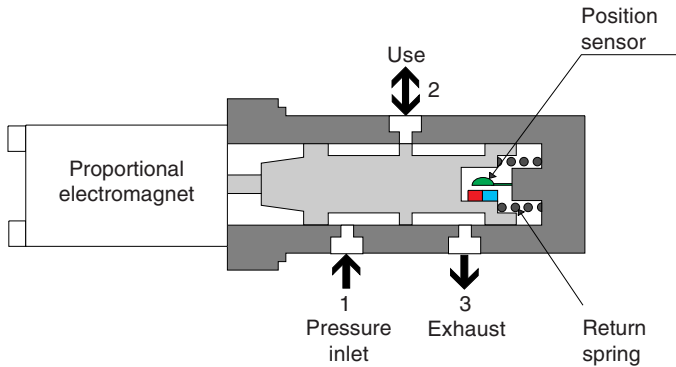

The position of the spool can be modified in continuous manner from a $\pm 10V$ set-point signal between the end positions.

Two versions of the SERVOTRONIC are available depending on the desired state of the **current cut-off** component ("Failsafe" position) :

- Pressure released (open center).

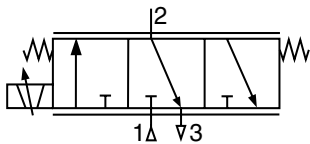

- Flow held (closed center).

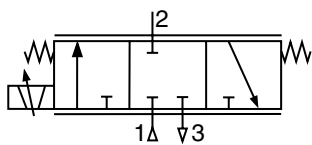

SERVOTRONIC ON PRESSURE CONTROL

The SERVOTRONIC series 607 in the pressure control version is a 3 port/3 position pressure control with electronic control supplying a pressure proportional to a given set-point.

The product includes :

- a pneumatic distributor consisting of matching **spool-sleeve assembly**.
- a **proportional electromagnet** directly controlling the movement of the spool.
- a **pressure sensor** located near the load port (2) supplying a signal proportional to the pressure obtained in the load volume.

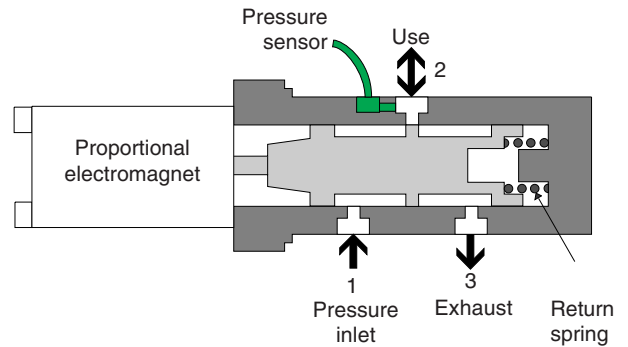

The position of the spool changes continuously to maintain a constant outlet pressure as function of a 0-10V set-point signal for a given pressure.

Two versions of the SERVOTRONIC are available depending on the desired state of the **current cut-off** component ("Failsafe" position) :

- Pressure released (open center).

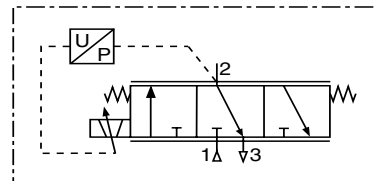

- Pressure held (closed center).

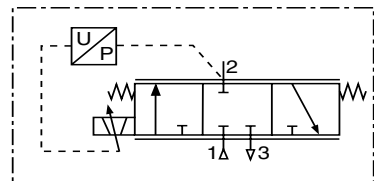

NOTE - Note that SERVOTRONIC is not a pneumatic isolating system and that its absolute tightness is not a necessary criterion for operation (maximum leakage flow-rate at 6 bar : 50 l/min - ANR).

SERVOTRONIC 3 PORT ELECTROPNEUMATIC PROPORTIONAL VALVE for FLOW-RATE control

SPECIFICATIONS

CONTROLLED FLUIDS	: Air or neutral gas, filtered to 5µm, without condensates, lubricated or not
CONNECTION	: G1/4
MAX ADMITTED PRESSURE (MAP)	: 10 bar
FLOW COEFFICIENT (as per ISO6358) when fully open:	
C	: $3.29 \times 10^{-8} \text{ m}^3/\text{s} \cdot \text{Pa}$ (sonic conductance)
b	: 0.44 (critical pressure ratio)
FLOW-RATE (Qv at 6 bar)	: 1400l/min (ANR), when fully open
MAX LEAKAGE (at 6 bar)	: 50l/min (ANR) (set-point at 0V)
FLUID TEMPERATURE	: +5°C to +40°C
AMBIENT TEMPERATURE	: +5°C to +40°C
SET-POINT-ANALOG	: + or - 10 Volts (Impedance 100 kΩ)
MECHANICAL RESPONSE TIME	: 5 ms (at 50% amplitude)
BANDWIDTH	: 150 Hz (at -3 dB, and at 50% amplitude)



CONSTRUCTION

Direct acting spool valve
Housing : treated light alloy
Internal parts : treated light alloy

INSTALLATION

Assembly position: any
Comply with required air quality
Comply with electrical supply specifications

ELECTRICAL CHARACTERISTICS

Connection diameter	DC voltage*	Max power (W)	Max current (mA)	Insulation class	Protection rating	Electrical connection
G 1/4	24V = +/-10%	30	1250	F	IP65	7-pin connector DIN43651

*Max ripple : 10%

Electromagnetic compatibility : electrostatic discharge IEC 801-2 level 3
fast electrical transience (coupling clip) IEC 801-4 level 3

EQUIPMENT SELECTION

Connection diameter	"Failsafe" current function	Load pressure (bar)	Max flow at 6 bar/ $\Delta P1$ bar (l/min-ANR)	CODES
G 1/4	 Pressure released (open center)	0 - 10	1400	607 00 005
	 Flow held (closed center)	0 - 10	1400	607 00 006

OPTION

Floating input (1) _____ code : **010643**
(1) Common mode voltage accepted : $\pm 24V$ to ground

ACCESSORIES

1 turn or 10 turn potentiometer } (See page 7)
Pressure sensor }

SERVOTRONIC 3 PORT ELECTROPNEUMATIC PROPORTIONAL VALVE

for PRESSURE control

SPECIFICATIONS

CONTROLLED FLUIDS	: Air or neutral gas, filtered to 5µm, without condensates, lubricated or not
CONNECTION	: G1/4
CONTROL RANGE	: 0-0.1 to 0-16 bar (see table below)
MAX ADMITTED PRESSURE (PMA)	: (see table below)
FLOW COEFFICIENT (as per ISO6358) when fully open:	
	C : $3.29 \times 10^{-8} \text{ m}^3/\text{s} \cdot \text{Pa}$ (sonic conductance)
	b : 0.44 (critical pressure ratio)
FLOW-RATE (Qv at 6 bar)	: 1400l/min (ANR), when fully open
MAX LEAKAGE (at 6 bar)	: 50l/min (ANR) (set-point at 0V)
FLUID TEMPERATURE	: +5°C to +40°C
AMBIENT TEMPERATURE	: +5°C to +40°C
SET-POINT - ANALOG	: 0 -10 Volts (Impedance 100 kΩ)
- DIGITAL (optional)	: 8 bits + memory function 8 bits + pressure reset
HYSTERESIS	: < 0,5 % of the PMR
INDEPENDENT LINEARITY	: < 0,1 % of the PMR



3

CONSTRUCTION

Direct acting spool valve
Housing : treated light alloy
Internal parts : treated light alloy

INSTALLATION

Assembly position: any
Comply with required air quality
Comply with electrical supply specifications

ELECTRICAL CHARACTERISTICS

Connection diameter	DC voltage*	Max power (W)	Max current (mA)	Insulation class	Protection rating	Electrical connection
G 1/4	24V = +/-10%	30	1250	F	IP65	7-pin connector DIN43651

*Max ripple: 10%

Electromagnetic compatibility : electrostatic discharge IEC 801-2 level 3
fast electrical transience (coupling clip) IEC 801-4 level 3

EQUIPMENT SELECTION

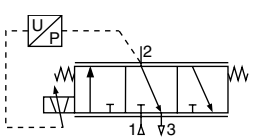
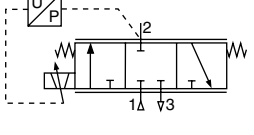
Connection diameter	Failsafe current function	Max flow at 6 bar/ ΔP 1 bar (l/min-ANR)	PMR control range (bar)	PMA (bar)	CODES
G 1/4	 Pressure released (open center)	1400	0 - 0.1	2	607 00 007
	 Pressure held (closed center)		0 - 0.5	2	607 00 008
				0 - 1	2
			0 - 3	8	607 00 010
			0 - 6	12	607 00 011
			0 - 10	12	607 00 012
			0 - 16	18	607 00 013
			0 - 0.1	2	607 00 014
			0 - 0.5	2	607 00 015
			0 - 1	2	607 00 016
			0 - 3	8	607 00 017
			0 - 6	12	607 00 018
			0 - 10	12	607 00 019
			0 - 16	18	607 00 020

OPTIONS

Analog set-point 0 - 20mA (Input impedance 500Ω)	code : 010644
Analog set-point 4 - 20mA (Input impedance 500Ω)	code : 010645
Floating input of set-point 0 - 20mA (1)	code : 010819
Floating input of set-point 4 - 20mA (1)	code : 010820
Pressure information output 0 - 20mA (max load 500Ω)	code : 010646
Pressure information output 4 - 20mA (max load 500Ω)	code : 010647
PNP pressure switch if set-point reached	code : 010648
NPN pressure switch if set-point reached	code : 010649
PNP pressure switch if set-point not reached	code : 010817
NPN pressure switch if set-point not reached	code : 010818
Digital set-point (8 bits + memory function)	code : 010650
Digital set-point (8 bits + pressure reset)	code : 010651
Additional spool control loop (2)	code : 010652

(1) Common mode voltage accepted: $\pm 24\text{V}$ to ground

(2) Optional loop for pressure release version (open center)

The loop is included in the pressure held standard version (closed center)

ACCESSORIES : See page 7

SERVOTRONIC series 607

DIMENSIONS AND WEIGHT

Weight : 1.100 kg

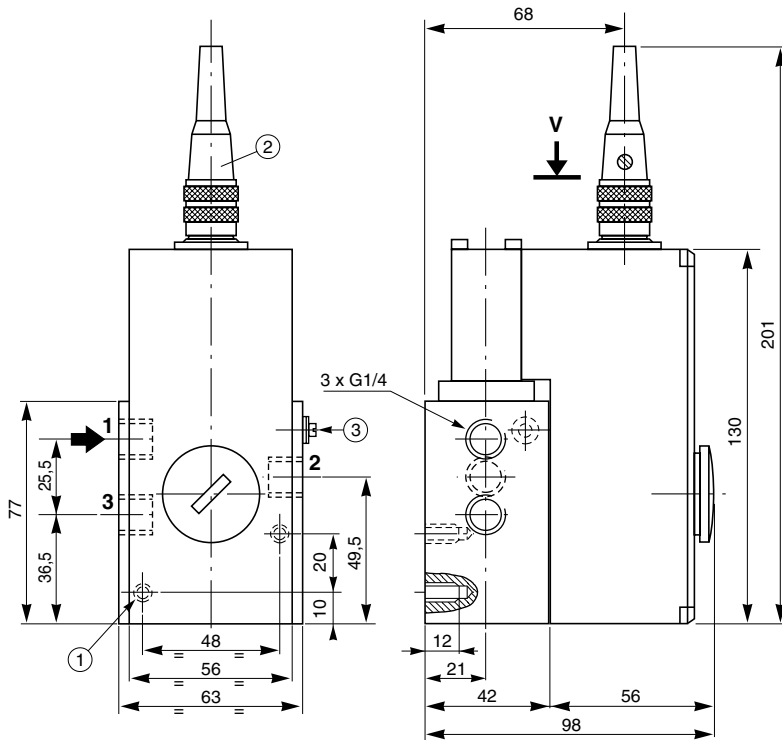

- ① - Lower attachment : 2 ØM5 holes
Tapped depth: 12 mm
- ② - Electric connection by plug-in connector
- ③ - External ground terminal

CONNECTION CONNECTORS

Version : **analog** set-point

view along "V"
(solder side of female connector)

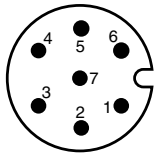

Flow control

- 1 - +24V power supply
- 2 - Ground (power supply)
- 3 - + set-point input
- 4 - Ground (set-point)
- 5 - Not connected
- 6 - Not connected
- 7 - Not connected

Pressure control

- 1 - +24V power supply
- 2 - Ground (power supply)
- 3 - + set-point input
- 4 - Ground (set-point)
- 5 - 12V stabilized voltage output
(30 mA max)
- 6 - Pressure signal (pressure sensor
output 0-10V for the pressure
range in question)
- 7 - Not connected (standard)
On option : pressure switch output
connection NPN or PNP
(500 mA max)

Version : **digital** set-point

view along "V"
(solder side of female connector)

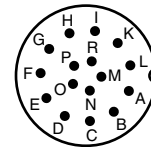

Pressure control

- A - +24V power supply
- B - Ground (power supply)
- C - Bit 1 (LSB)
- D - Bit 2
- E - Bit 3
- F - Bit 4
- L - Memory function (option 010650)
Pressure reset function (option 010651)
- M - Not connected (standard)
On option: pressure switch output
connection NPN or PNP (500 mA max)
- N - Not connected
- O - Not connected
- P - Pressure signal (pressure sensor
output 0-10V for the pressure
range in question)
- R - Not connected
- G - Bit 5
- H - Bit 6
- I - Bit 7
- K - Bit 8 (MSB)

The digital set-point version is not proposed in the flow control mode.

ACCESSORIES FOR SERVOTRONIC CONTROL

To meet the complementary requirements of control installations, JOUCOMATIC proposes the following accessories:

RELATIVE PRESSURE SENSORS

Associated with the SERVOTRONIC, for FLOW control, these sensors transmit upstream and downstream relative pressure information in order to calculate the real flow-rate after taking the atmospheric pressure value into consideration.

EQUIPMENT SELECTION

Pressure range (bar)	CODES	
	Voltage output 0 - 10V	Current output 0 - 20 mA
0 - 20	603 00 022	603 00 027
0 - 10	603 00 023	603 00 028
0 - 5	603 00 024	603 00 029
0 - 3	603 00 025	603 00 030
0 - 2	603 00 026	603 00 031
0 - 1	603 00 104	603 00 105



DIMENSIONS

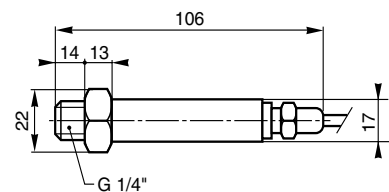

ELECTRICAL CHARACTERISTICS

- Power supply voltage : 24V DC= ±10%
- Protection level : IP 65
- Precision class : 0.5
- 3 conductor cable output, length 2m
Brown = +24V
White = output
Green = ground

SET-POINT POTENTIOMETER

Combined with the SERVOTRONIC unit, for PRESSURE control, the potentiometer provides manual control of the set-point.

EQUIPMENT SELECTION

Designation	CODE
1 turn adjustment	603 00 042
Fine 10 turn adjustment	603 00 043

Ohmic value: 10 kΩ (linear)



Photo : model / fine adjustment, 10 turns

DIMENSIONS

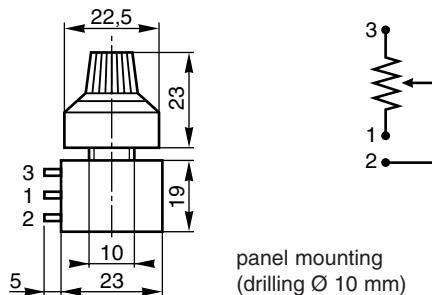

panel mounting
(drilling Ø 10 mm)

ASCO/JOUCOMATIC reserves the right to alter the availability and specifications without notice.

